

# BVRDADC

## Installation Manual

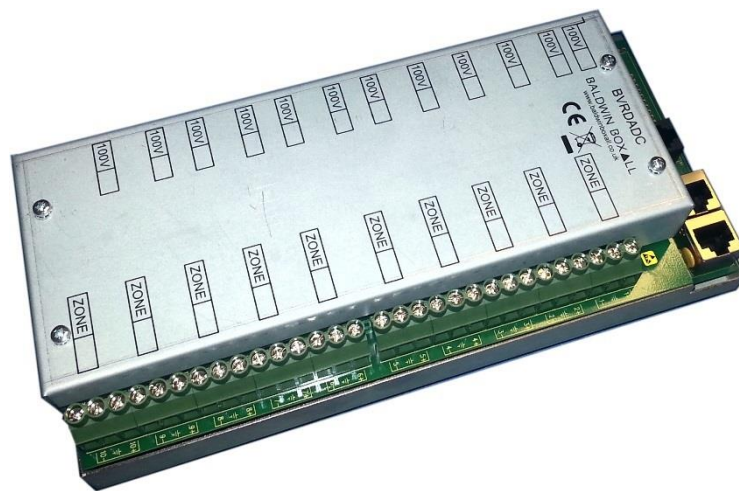

**Baldwin Boxall Communications Ltd.**  
Wealden Industrial Estate, Farningham Road  
Crowborough, East Sussex, TN6 2JR

Telephone: 01892 664422

Fax: 01892 663146

Website: [www.baldwinboxall.co.uk](http://www.baldwinboxall.co.uk)

Email: [mail@baldwinboxall.co.uk](mailto:mail@baldwinboxall.co.uk)

# VIGIL BVRDADC

## Description of unit

The Vigil BVRDADC is a loudspeaker line monitor and amplifier changeover unit, for use with VIGIL amplifiers and the BVRD2M router.

Each unit is supplied as a DIN rail-mounting module, with screw terminals for connections to the amplifiers and loudspeaker lines. Connection to the BVRD2M is by CAN BUS ports.

## Amplifier changeover function

Each unit consists of ten channels that can be utilised for either dual or single circuit systems. For dual circuits ten working amplifiers (five dual circuits) and one standby amplifier can be accommodated. For single circuit systems ten working amplifiers (ten single circuits) and one standby amplifier are available.

If an amplifier were to fail the BVRDADC automatically detects the faulty amplifier and switches over to a reserve amplifier until the fault has been rectified. A fault will be displayed on the BVRD2M front panel and also stored in the BVRD2M fault log.

When the faulty amplifier has been replaced it is necessary to press the "Fault Reset" button on the front of the BVRD2M to restore the system and stop using the reserve amplifier.

## Loudspeaker line monitor function

Each loudspeaker line (including spurs) must have an End of Line resistor fitted in parallel with the last physical loudspeaker on the line. All loudspeakers must be fitted with a DC Blocking capacitor, see illustration below for details.

The BVRDADC monitors the integrity of the Loudspeaker Line by measuring a small DC current flowing through the End of Line resistors. Any change in this current indicates either a short circuit or open circuit condition on the loudspeaker line.

Earth faults are also detected.

## DC Blocking Capacitor & End of Line Resistor Values

Speaker Wattage	6 Watts	15 Watts	30 Watts	60 Watts
Capacitor Requirements	1 $\mu\text{f}$ 250V DC	2.2 $\mu\text{f}$ 250V DC	4.7 $\mu\text{f}$ 250V DC	10 $\mu\text{f}$ 250V DC
End of Line Resistor	High Stability 10K $\Omega$ 2W 1% (Our Part # <b>BVRDADCR</b> )			

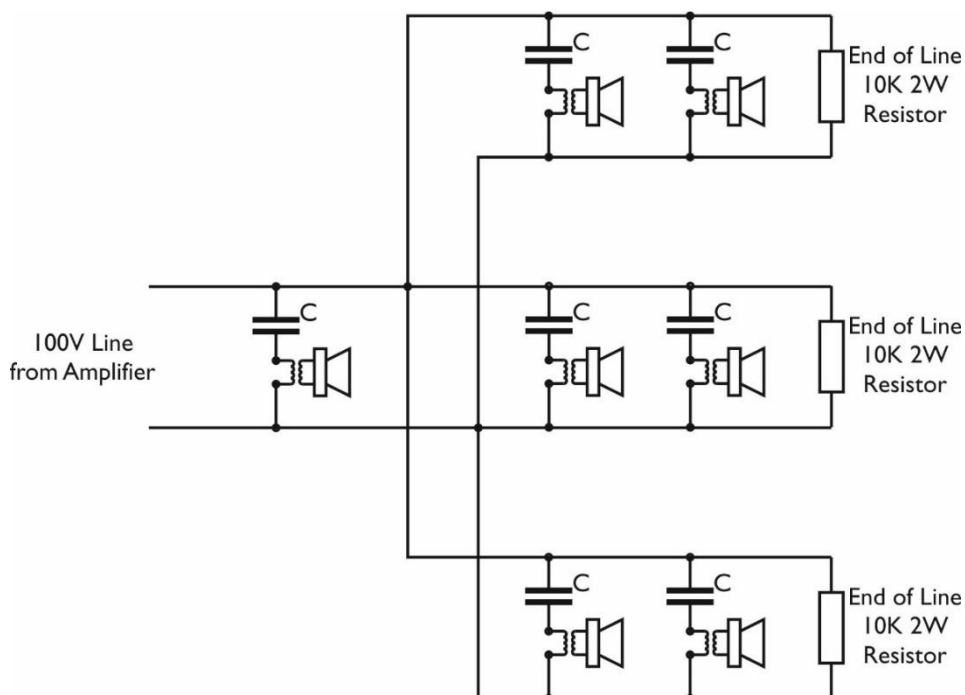

## BVRDADC Installation Procedure

### Calibration

- 1 Note the current positions of SW1.1 to SW1.4 if the CANBUS address has been set.
- 2 Ensure all individual loudspeakers are fitted with a DC Blocking Capacitor and tapped to produce the required maximum sound level.  
Ensure the End of Line resistor(s) are the correct value and connected in parallel with the last loudspeaker on each loudspeaker line (on the line side of the DC Blocking capacitor).
- 3 Disconnect the individual loudspeaker line(s) from the BVRDADC module.
- 4 Using an impedance meter set to 1kHz, measure and record the impedance. Ensure the load does not exceed the amplifiers rating.
- 5 Using a digital multi meter, measure and record the DC resistance. Divide this value into 10,000 and ensure the result equals the number of End of Line resistors connected.
- 6 Reconnect the line to the appropriate output terminals on the BVRDADC module.
- 7 Repeat steps (2) to (6) for all speaker lines to be connected to the BVRDADC module.
- 8 Set SW1.5 to 'ON' (with SW1-4 set to 'OFF') and press the Calibrate switch to set the calibrate reference for all 10 lines.  
It is necessary to wait approximately 60 seconds to allow the BVRDADC to cycle through the calibration process for all lines.
- 9 Set SW1.5 to 'OFF' and SW1.1 - 1.4 to original positions to enable normal operation.

### To calibrate an individual line:

Note the positions of SW1.1 to SW1.4.

Select the required line using SW1 as shown below and press the calibrate switch.

After calibrating return SW1.1 - 1.4 to the required address, and ensure SW1.5 is set to "OFF".

	SW1					Line
	6	5	4	3	2	1
X	1	0	0	0	1	1
X	1	0	0	1	0	2
X	1	0	0	1	1	3
X	1	0	1	0	0	4
X	1	0	1	0	1	5
X	1	0	1	1	0	6
X	1	0	1	1	1	7
X	1	1	0	0	0	8
X	1	1	0	0	1	9
X	1	1	0	1	0	10
X	1	0	0	0	0	All lines

## Set CANBUS Address

To enable the BVRDADC module to communicate with the BVRD2M it requires a unique CANBUS address to be set using SW1 as shown below.

Note: SW1.6 is used for the CANBUS termination – 1 = Terminated, 0 = Unterminated.

SW1						Address
6	5	4	3	2	1	
X	0	0	0	0	0	0
X	0	0	0	0	1	1
X	0	0	0	1	0	2
X	0	0	0	1	1	3
X	0	0	1	0	0	4
X	0	0	1	0	1	5
X	0	0	1	1	0	6
X	0	0	1	1	1	7
X	0	1	0	0	0	8
X	0	1	0	0	1	9
X	0	1	0	1	0	10
X	0	1	0	1	1	11
X	0	1	1	0	0	12
X	0	1	1	0	1	13
X	0	1	1	1	0	14

## Operation of the BVRDADC with the BVRD2M

The BVRD2M will display the following messages if a Line / Amplifier fault is detected:

“L/S Line O/C”	The system has detected the Loss of one or more End of Line resistors (DC resistance of the line has increased from calibrated value).
“L/S Line S/C”	The system has detected a Short Circuit (DC resistance of the line has decreased from calibrated value).
“AMP FAULT”	The system has detected an Amplifier Fault
“RES AMP”	The system has detected a fault with a Reserve Amplifier.
“GND FAULT”	The system has detected a loudspeaker line connected to Ground (Earth).

The BVRDADC does not have a “Return Voltage” as it is a DC line monitor, however as an aid to the operator the BVRD2M displays the number of End of Line resistors found on each output.

On the BVRD2M Amplifier Surveillance page each 0.5V of the displayed Return Voltage equates to 1 End of Line Resistor (e.g. 3.5V equates to 7 End of Line resistors).