

Assistance Call Solutions



Combine a disabled refuge outstation with a pull cord and over-door light for an alternative assistance call solution.

Simply connect a refuge remote to the OmniCare panel in the normal way. Then add a ceiling pull and over-door light to complete.

This combination adds versatility to our OmniCare EVC product range.

OmniCare

THE PRODUCTS:

Disabled Refuge Outstation:

- The BVOCECPG (green) or BVOCECPS (stainless steel) remote unit with call button and reset keyswitch provides two-way, hands free speech communication.

Bezel:

- The BVCRMGRN (green) or BVCRMSS (stainless steel) optional flush mounting bezel for the refuge remote.

Pull Cord:

- The DTACP (white) or DTASCP (stainless steel) ceiling mounted pull switch with two 'G' pulls.

Light/sounder:

- The DTAODLR (white) or (DTASODLR) stainless steel over-door triangular lens with integral sounder to attract attention.

OPERATION:

- Calls for assistance can be initiated either by pulling the ceiling mounted pull cord, or by pressing the button on the refuge outstation.
- The call will be announced visually and audibly both at the point of call and at the control panel.
- The operator at the control panel will accept the call and two-way speech communication will be immediately available.
- Following assistance, the call can either be reset at the control panel or by the key switch on the refuge outstation.

THE BENEFITS:

- Two methods to call for attention - pull cord or button on the remote unit.
- Hands free two way speech communication.
- Assess the nature of the call prior to responding - provides the ability to gather extra assistance if required.
- Accidental calls can be identified and cancelled without moving away from the control panel.
- Multiple units can be connected on a single cable loop.
- Each refuge point has a separate button indicator at the control panel, with status indication LEDs.
- No local power is necessary - all items are powered via the control panel.
- Proven OmniCare quality and technology.

GENERAL:

- Fully conforms to BS5839-9:2021 requirements.
- Fully monitored and battery backed.
- The disabled refuge outstation is connected to the OmniCare system control panel on a loop circuit.

[Click for information on the OmniCare system](#)

Specifications:

Disabled Refuge Remote Unit	
Product code	BVOCECPG/S
Power supply	12-40V DC self powered from ring circuit
Power consumption	30mA @ 35V typical
Humidity range	95% non-condensing
Temperature range	-10°C to +40°C
Indicators	System healthy, status
Finish	Green RAL 6024 / Stainless Steel grade 304
Dimensions (mm) WxHxD	134 x 134 x 56
Weight	1 kg
Knockouts/cable entry points	7 (20mm & 26mm)
Bezel dimensions (mm)WxH (radius)	154 x 154 (10)
Bezel cut out (mm) WxH	136 x 136

	Over-door light / sounder	Ceiling pull
Product code	DTAODLR/DTASODLR	DTACP/DTASCP
Alarm type	90dB @ 30cm	
Dimensions (mm) WxHxD	85x85x58	White: 30 x 80diam S/S: 85 x 85
Finish	White plastic / stainless steel grade 304	

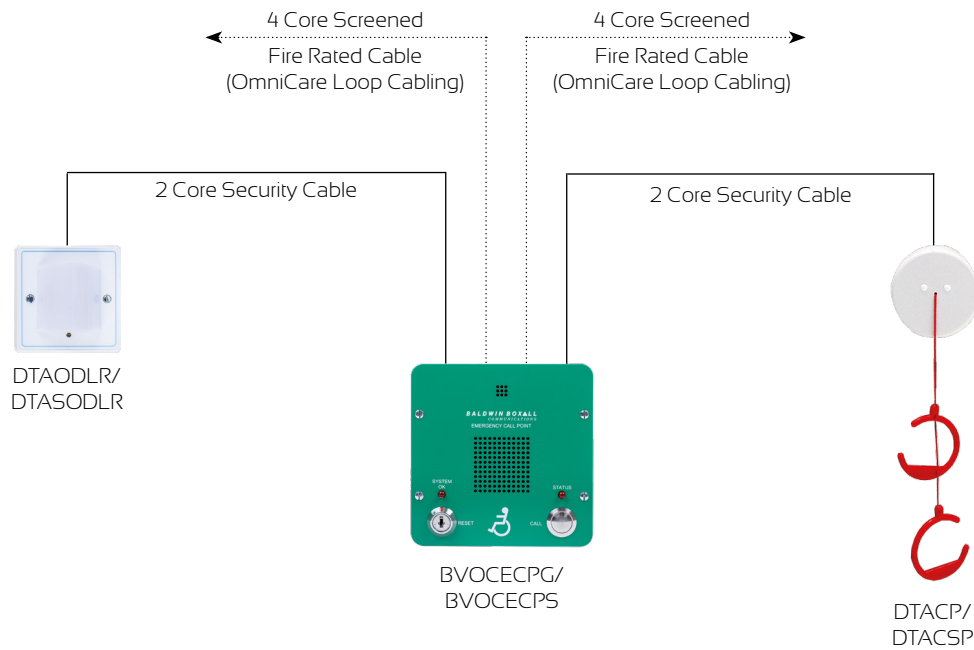

BALDWIN BOXALL
LEADING THE WAY TO SAFETY

Baldwin Boxall Communications Ltd
Wealden Industrial Estate, Farningham Road,
Crowborough, East Sussex, TN6 2JR, United Kingdom

T: +44 (0) 1892 664422
E: hello@baldwinboxall.co.uk
W: www.baldwinboxall.co.uk